



Training Plan

For Professionals in Commercial Vehicles and Light Vehicles





INDEX



1.- Training, the BEST PATH	3	3.8.- Trailer	44
2.- New		3.9.- Light commercial vehicle	47
2.1.- General	5	3.10.- Agricultural Vehicles	50
2.2.- New courses	5	3.11.- Jaltest Specialist	53
3.- Courses	6	4.- Training interest form	55
3.1.- Diagnosis	8		
3.2.- Electricity	12		
3.3.- Pneumatics	16		
3.4.- Engine management	22		
3.5.- Gearbox	29		
3.6.- Comfort systems	34		
3.7.- Brands	36		





1. Training, the BEST PATH

“Give me a lever, and I shall move the world”.

“Give me training and I shall make a lever capable of moving the world”.

The first quote was written by Archimedes, the second one by COJALI. These are the principles we work with everyday in our group of companies. Always seeking new information, continuously improving.

For this reason, when any of us want to make progress, besides a great amount of effort, we must add knowledge.

COJALI, one of the few companies that promotes this knowledge as a source of progress, has chosen the path of training.

This path has been chosen by more than 5.200 people from 37 different countries.

What about You? Have you chosen your Path?



2. NEW

2.1. General

- **Interactive Practice** tests for every training course.

Many times, when completing a training course, we do not know what we have learnt.

In order to acknowledge the level acquired, each one of Jaltest e-learning training courses has a THEORETICAL/PRACTICAL TEST associated.

Learning assessment, easy and entertaining, after doing a Jaltest e-learning course.



2.2. New courses

Gearbox:

- C0503: "Scania Opticruise gearbox. Disassembly, assembly and checking of failures"
- C0504: "Mercedes-Benz Powershift gearbox. Disassembly, assembly and checking of failures"

Agricultural Vehicles:

- C3201: "Jaltest AGV. Use of the device and diagnostics"



3. COURSES (2 days, 16 hours - 75% practical training)

Diagnosis

- C0101 · Jaltest. Use of the device and diagnostics. 📄
- C0102 · Advanced diagnosis. Service reset, calibrations and direct diagnosis on ECUs.
- C0103 · Jaltest expert mode. Calibrations and modification of parameters.

Electricity

- C0201 · Electricity in commercial vehicles. Reading of wiring diagrams.
- C0202 · Electricity in commercial vehicles. Checking of sensors and electrical components. 📄
- C0203 · CAN lines. Diagnosis and electrical checks.

Pneumatics

- C0301 · Pneumatics. Reading of pneumatic diagrams.
- C0302 · EBS in trucks. Diagnostics, diagrams and system checks. 📄
- C0303 · Suspension. Diagnostics, calibration of sensors and modification of parameters in ECAS.
- C0304 · Compressed air generation. Diagnosis and configuration of parameters.
- C0305 · ABS/ASR in trucks. Diagnostics, diagrams and system checks.

Engine Management

- C0401 · EDC. System diagnosis, calibration of injectors and engine adjustment. 📄
- C0402 · Euro IV and Euro V/EEV. Diagnosis and checking of AdBlue/DEF Systems.
- C0403 · Common - Rail. Diagnosis and checking of fuel systems. 📄
- C0404 · Turbocompressors. Efficiency tests and calibrations.
- C0405 · Fans. Efficiency tests and configuration.
- C0406 · Euro 6. Diagnosis of exhaust gases after-treatment systems. 📄

Gearbox

- C0501 · ZF AS Tronic gearbox. Disassembly, assembly and checking of failures.
- C0502 · Volvo I-Shift/Renault Optidriver gearbox. Disassembly, assembly and checking of failures.
- C0503 · Scania Opticruise gearbox. Disassembly, assembly and checking of failures. 📄
- C0504 · Mercedes-Benz Powershift gearbox. Disassembly, assembly and checking of failures. 📄





3. COURSES

Courses (2 days, 16 hours - 75% practical training)

Comfort Systems

C0601 · Installation of refrigeration systems with fluorinated refrigerants for the thermal comfort of human beings in vehicles.

Brands

- C0701** · Iveco. Diagnosis of EDC systems.
- C0702** · MAN TGA. Frequent failures.
- C0703** · Mercedes-Benz Actros 2/3. Frequent failures.
- C0704** · Iveco Stralis. Frequent failures.
- C0705** · Renault Premium DXi. Frequent failures.
- C0706** · MAN. Diagnosis of EDC systems.
- C0707** · Renault. Diagnosis of EDC systems.

Trailer

- C1001** · ABS trailer. Diagnosis and configuration of parameters. 
- C1002** · EBS trailer. Diagnosis and configuration of parameters.

Light commercial vehicle

- C2301** · ABS in light commercial vehicles. Diagnostics, diagrams and system checks.
- C2401** · EGR, particulate filters and AdBlue in light commercial vehicles. Diagnosis, reset and regeneration.

Agricultural Vehicles

- C3101** · Jaltest AGV. Use of the device and diagnostics. 
- C3201** · Electricity in agricultural vehicles. Reading of wiring diagrams. 

Jaltest Specialist

- C9901** · Repair methods in commercial vehicles.

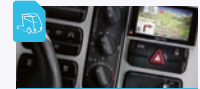

COMFORT SYSTEMS



BRANDS



TRAILER



LCV



AGRICULTURAL VEHICLES



JALTEST SPECIALIST

3.1 Diagnosis

■ C0101 · Jaltest. Use of the device and diagnostics 	9
■ C0102 · Advanced diagnosis. Service reset, calibrations and direct diagnosis on ECUs.....	10
■ C0103 · Jaltest expert mode. Calibrations and parameters modification.....	11





C0101

JALTEST. USE OF THE DEVICE AND DIAGNOSTICS

Description

Theoretical-practical course.

The goal of this course is to acquire the necessary knowledge of the main systems with electronic control for the correct interpretation of the diagnosis in commercial vehicles.

Diagnosis is performed in the different systems with electronic control described theoretically.

Objective

The main purpose is to qualify the technician so he can deal with failures, performing diagnosis in the main systems of commercial vehicles such as:

- Injection
- Gearbox
- Maintenance
- Retarder
- Brakes
- Suspension

Net Price:
500 €

Duration_16 Hours





C0102

ADVANCED DIAGNOSIS. SERVICE RESET, CALIBRATIONS AND DIRECT DIAGNOSIS ON ECUs

Description

Theoretical-practical course.

The diagnosis knowledge in commercial vehicles is broaden.

Analysis of failures causing an incorrect development within the procedure of the maintenance system.

Study of the main communication protocols in a theoretical and practical way, in order to acquire the necessary skills to perform diagnosis individually in electronic control units without the need of a truck or trailer.



Objective

Learn and be able to perform maintenance services with electronic control with a diagnosis tool or any other way that may proceed.

Learn and be able to perform diagnosis from any point of the commercial vehicle.

Note

The course description and its objectives indicate that it is advisable to have a basic knowledge on Diagnosis and Electricity in order to achieve such goals in an optimal way.

Duration_16 Hours





C0103

JALTEST EXPERT MODE. CALIBRATIONS AND PARAMETERS MODIFICATION

Description

Theoretical-practical course.

The special functions which are performed with Jaltest in "Expert Mode" are described. These Jaltest special functions are those in which the parameters of the ECU are modified. With this option, the user can access expert diagnostics functions in different systems. These functions will be performed when the device is configured in "Expert Mode". The special functions affecting the vehicle security and pollution are described.

Objective

Know every function performed by Jaltest in expert mode technically.

..... *Duration_16 Hours*

Net Price:
500 €

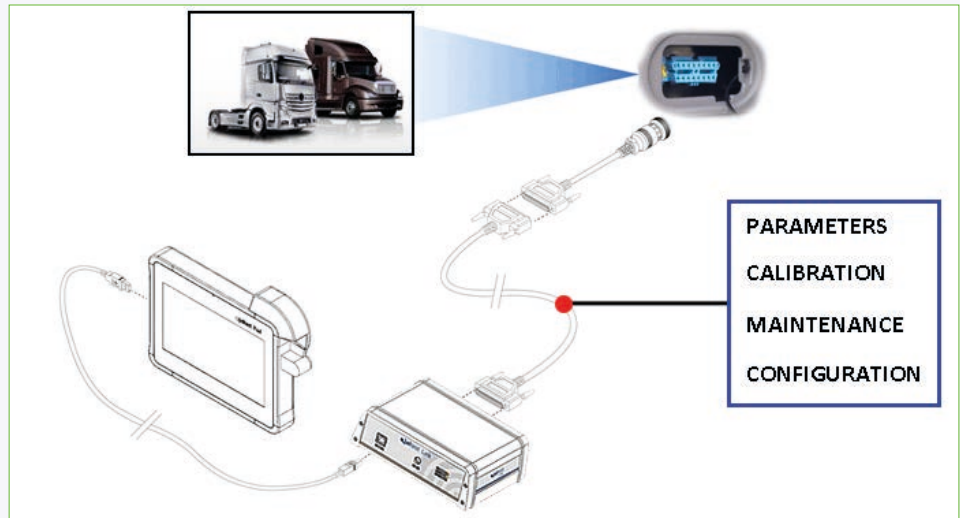

3.2 Electricity

■ C0201 · Electricity in commercial vehicles. Reading of wiring diagrams.....	13
■ C0202 · Electricity in commercial vehicles. Checking of sensors and electrical components 	14
■ C0203 · CAN lines. Diagnosis and electrical checks.....	15

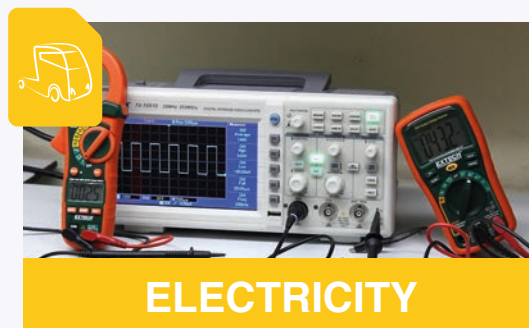



C0201

ELECTRICITY IN COMMERCIAL VEHICLES. READING OF WIRING DIAGRAMS

Description

Theoretical-practical course.

Study of the basic concepts of electricity, such as: tension, direct current, alternating current, resistance, power, short circuits, open circuits, square signals...

The hands on will be conducted on electronic diagnosis boards, where the different electronic components will be checked, and electronic circuits will be designed, based on the practices proposed in the course.

Objective

Handling of the multimeter by dealing with real failures caused on test benches.

Ability to differentiate between the main units of measurement and electrical parameters.

Net Price:
500 €

Duration_16 Hours

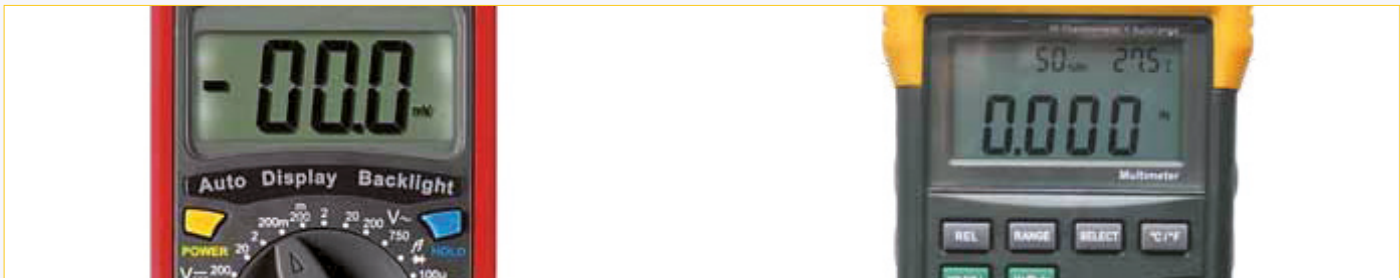



C0202

ELECTRICITY IN COMMERCIAL VEHICLES. CHECKING OF SENSORS AND ELECTRICAL COMPONENTS

Description

Theoretical-practical course.

Interpretation and checking of wiring diagrams, sensors and electronic components from different brands of commercial vehicles with the help of the appropriate documentation and material.

Verification of sensors such as pressure sensors, height sensors, brake signal transmitters, fan clutches with electronic control (coil and hall sensor) by interpreting the graphs and with the help of a multimeter and an oscilloscope.



Objective

Operate the multimeter in an advanced way.

Analyse electrical signals both theoretically and practically with the help of an oscilloscope.

Note

The course description and its objectives indicate that it is advisable to have a basic knowledge on Diagnosis and Electricity in order to achieve such goals in an optimal way.

Duration_16 Hours

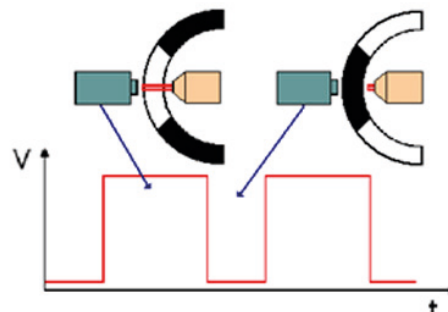
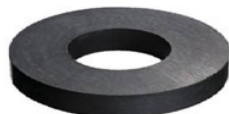



C0203

CAN LINES. DIAGNOSIS AND ELECTRICAL CHECKS

Description

Theoretical-practical course.

Study of the main CAN electronic structures on every commercial vehicle and trailers.

Interpretation of diagnosis errors caused by CAN lines.

Study of CAN protocols.



Net Price:
500 €

Visualization of CAN lines with an oscilloscope and interpretation.

Practical expert analysis of signals with an oscilloscope.

Objective

Expert handling of multimeter and oscilloscope.

Learn to check a CAN lines installation in a practical way verifying failures on vehicles.

Duration_16 Hours

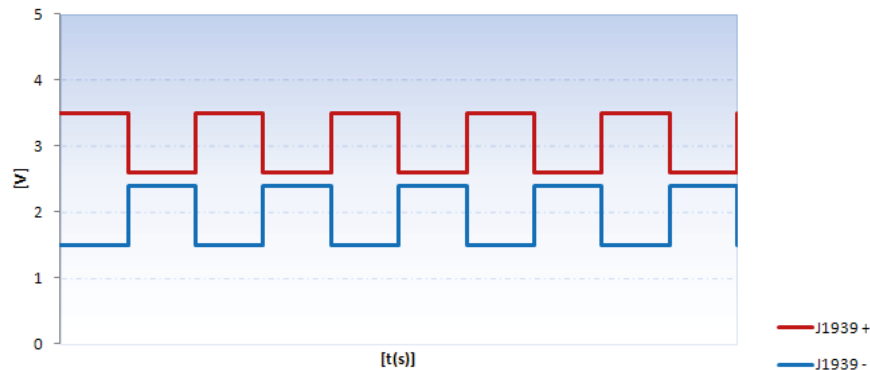
SAE J1939

3.3 Pneumatics

■ C0301 · Pneumatics. Reading of pneumatic diagrams.....	17
■ C0302 · EBS in trucks. Diagnostics, diagrams and system checks 	18
■ C0303 · Suspension. Diagnostics, calibration of sensors and modification of parameters in ECAS.....	19
■ C0304 · Compressed air generation. Diagnosis and configuration of parameters.....	20
■ C0305 · ABS/ASR in trucks. Diagnostics, diagrams and system checks.....	21





C0301

PNEUMATICS. READING OF PNEUMATIC DIAGRAMS

Description

Theoretical-practical course.

Study of compressed air generation systems, brake systems and air suspension systems.

With the help of a test bench, the following will be verified: wiring diagrams, pressure graphs and air brake and suspension valves (both for trucks or trailers) such as: trailer control, quadruple protection, parking brake, pressure relief, pressure regulator, relay valve, ALB Pneumatics, ALB-Mechanics, 3/2-way, height control...

Objective

Learn the basics of the compressed air generation system.

Analyse the basics of the brake system, learn its components and the function they perform within the system.

Analyse the basics of the air suspension system, learn its components and the function they perform within the system. Introduction to the electronically controlled ABS pneumatic systems.



Duration_16 Hours

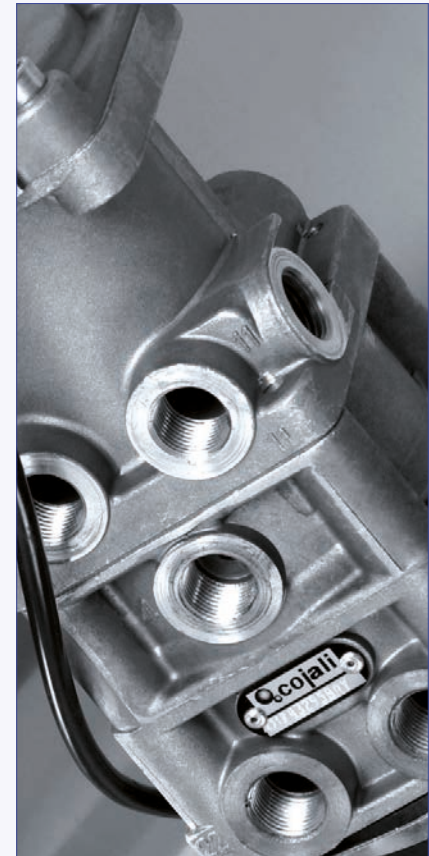



C0302

EBS IN TRUCKS. DIAGNOSTICS, DIAGRAMS AND SYSTEM CHECKS

Description

Theoretical-practical course.

This course brings together electricity and pneumatics, therefore, a brief review of said concepts will be carried out.

Detailed analysis of the operation of each of the electronically controlled valves and complete interpretation of electro-pneumatic diagrams in brake systems of the main manufacturers.

Net Price:
500 €

Objective

Learn to relate electricity, pneumatics and diagnosis collectively in order to be able to deal with as many errors as possible. Learn to differentiate between systems with and without electronic control. Learn the operation of the electronic control of the braking based on the load. Learn the operation of the electronically controlled brake systems.

Note

The course description and its objectives indicate that it is advisable to have a basic knowledge on Diagnosis and Electricity in order to achieve such goals in an optimal way.

..... *Duration_16 Hours*

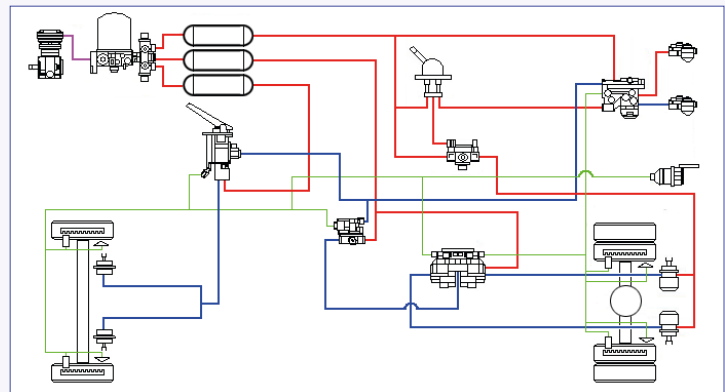



C0303

SUSPENSION. DIAGNOSTICS, CALIBRATION OF SENSORS AND MODIFICATION OF PARAMETERS IN ECAS

Description

Theoretical-practical course.

Study of the operation of the electronically controlled air suspension (ECAS) valves. Analysis of the components such as:

- *Electronically Controlled Air Suspension ECAS*
- *Height sensor*
- *Pressure sensor*
- *Air suspension pressure sender*
- *3/2 channel valve for ALB control*



Objective

Learn to interpret electro-pneumatic diagrams in ECAS and the operating of its components. Train the assistants to calibrate the suspension with Jaltest.

Note

The course description and its objectives indicate that it is advisable to have a basic knowledge on Pneumatics and Electricity in order to achieve such goals in an optimal way.

Duration_16 Hours

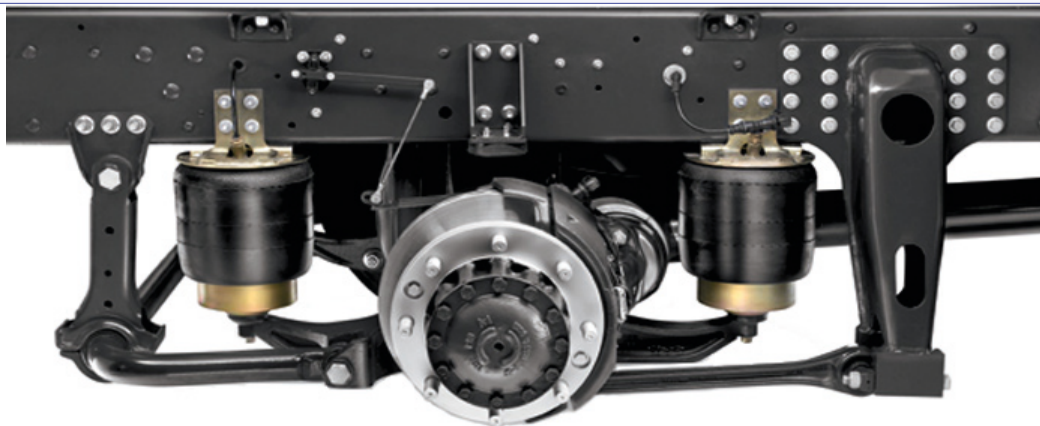



C0304

COMPRESSED AIR GENERATION. DIAGNOSIS AND CONFIGURATION OF PARAMETERS

Description

Theoretical-practical course.

Study of the compressed air generation and treatment systems in commercial vehicles from different manufacturers such as:

- ECAM (Electronically Controlled Air Management)
- APU (Air Processing Unit)
- E-APU (Electronic Air Processing Unit)
- ECAD (Electrically Controlled Air Dryer)
- EAC (Electronic Air Control)

Net Price:
500 €

Objective

Learn the mechanic and electronically controlled systems for the generation and treatment of compressed air. Train the technician so he learns about the maintenance of electronically controlled air dryers with a diagnosis tool or any other way that may proceed.

..... Duration_16 Hours

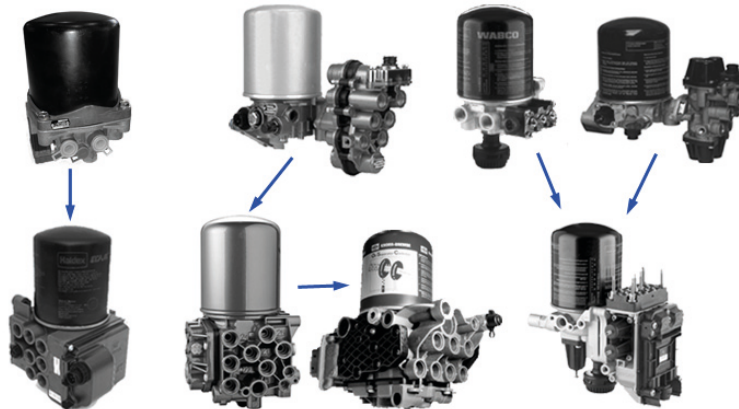



C0305

ABS/ASR IN TRUCKS. DIAGNOSTICS, DIAGRAMS AND SYSTEM CHECKS

Description

Theoretical-practical course.

Study of the different ABS systems developed in commercial vehicles and analysis of its components such as:

- ABS/ASR C
- ABS/ASR D
- ABS E
- ABS 2X



- ABS/ASR Gamma 2E
- ABS CP12 (Gama 3E)
- ABS/ASR Ci12
- ABS/ASR 24 / EU12
- ABS 6



Objective

Learn the operation and regulation of the main ABS/ASR system in commercial vehicles, as well as its components.

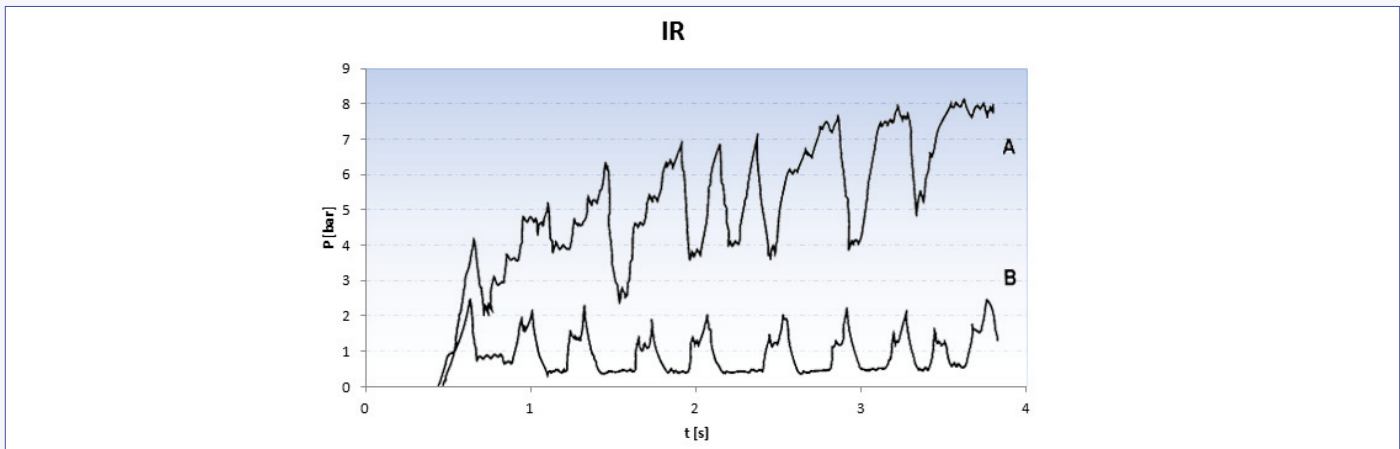
Duration_16 Hours



3.4 Engine Management

■ C0401 · EDC. System diagnosis, calibration of injectors and engine adjustment 	23
■ C0402 · Euro IV and Euro V/EEV. Diagnosis and checking of AdBlue/DEF Systems.....	24
■ C0403 · Common - Rail. Diagnosis and checking of fuel systems 	25
■ C0404 · Turbocompressors. Efficiency tests and calibrations.....	26
■ C0405 · Fans. Efficiency tests and configuration.....	27
■ C0406 · Euro 6. Diagnosis of exhaust gases after-treatment systems 	28





C0401

EDC. SYSTEM DIAGNOSIS, CALIBRATION OF INJECTORS AND ENGINE ADJUSTMENT

Description

Theoretical-practical course.

Study of the Electronic Diesel Control (EDC) systems such as: Unit Injector System (UIS), Unit Pump System (UPS) and Common-Rail (CR). The hands on will be conducted on engines and on components of injection and commercial vehicles such as: valves adjustment and injectors precharging, synchronization and phasing between the flywheel and the distribution, diagnosis of EDC in vehicles and solving of caused breakdowns.

Objective

Differentiate the main EDC systems, their components and the function they perform within the system. Learn the sensing of the EDC system and the operation of the control unit. Interpret the diagnosis and verify the errors.

Net Price:
500 €

Duration_16 Hours





C0402

EURO IV AND EURO V/EEV. DIAGNOSIS AND CHECKING OF ADBLUE/DEF SYSTEMS

Description

Theoretical-practical course.

Description of the components that make up the exhaust gases aftertreatment system and study of the operation of the system as a whole. Study of the AdBlue system from the main brands of commercial vehicles. Interpretation and verification of diagnosis and errors on this system.



Objective

Learn the operation of the main valves, components and sensors of EDC and AdBlue. Verify the actuation and measuring possibilities on EDC and AdBlue systems with Jaltest. Learn the operation of the EDC unit and how it is related to the AdBlue system. Interpret and verify diagnosis and errors on this system.

Duration_16 Hours





C0403

COMMON - RAIL. DIAGNOSIS AND CHECKING OF FUEL SYSTEMS

Description

Theoretical-practical course.

Detailed study of the Common - Rail system and its components, of both the low and high pressure parts.

Components of low pressure part:

- Fuel tank with pre-filter.
- Pre-pump.
- Fuel filter.
- Low pressure fuel pipes.

Components of high pressure part:

- High pressure pump with pressure relief valve.
- High pressure fuel pipes.
- Rail as high pressure accumulator with Rail pressure sensor, pressure relief valve and flow limiter-
- Injectors.
- Fuel return pipes.

Common-Rail injection system studied:

- DAF: ECS-DC3 & DC4
- IVECO: EDC7 & EDC7 UC31
- MAN: EDC 7
- MERCEDES-BENZ: MCM
- RENAULT: dCi
- SCANIA: EMS XPI
- VOLVO: EMS

Net Price:
500 €

Duration_16 Hours





C0404

TURBOCOMPRESSORS. EFFICIENCY TESTS AND CONFIGURATION

Description

Theoretical-practical course.

Study of the boost systems of internal combustion engines and the relation between the turbo and the EDC system.

Description of the assembly and performance of turbos in the main European brands.

Practical training in different vehicles, analysing and measuring the parameters of the turbocompressor through diagnosis.

Net Price:
500 €

Objective

Learn the performance of the different types of turbocompressors as well as the components for its control:

- Wastegate valve
- VGT

Correctly diagnose failures in the turbocompressors from the 7 main European brands using Jaltest.

Duration_16 Hours





C0405

FANS. EFFICIENCY TESTS AND CONFIGURATION

Description

Theoretical-practical course.

Study of the types of clutches depending on the kind of engagement and engagement control.

- Friction fan clutch with electromagnetic control
- Viscous clutch with bimetallic control
- Viscous fan clutch with pneumatic control
- Viscous fan clutch with electronic control

Objective

Know and analyse the operation of the different types of clutches.

Net Price:
500 €

Duration_16 Hours





C0406

EURO 6. DIAGNOSIS OF EXHAUST GASES AFTER-TREATMENT SYSTEMS

Description

The exhaust gases aftertreatment systems in Euro 6 vehicles are described.

These systems can be divided into two groups:

- *SCRY System, Selective Catalytic Reduction.*
- *DPF System, Diesel Particulate Filter.*

Objective



Know and analyse the exhaust gases aftertreatment systems in Euro 6 vehicles.

Net Price:
500 €

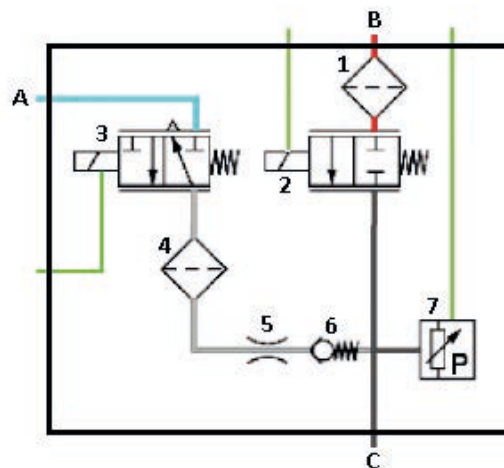
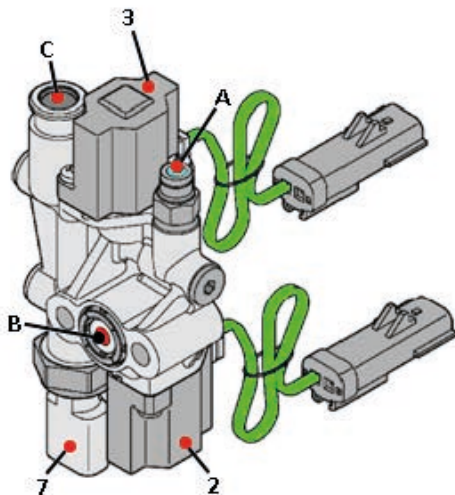
Duration **16 Hours**



3.5 Gearbox

■ C0501 · ZF AS Tronic gearbox. Disassembly, assembly and checking of failures.....	30
■ C0502 · Volvo I-Shift/Renault Optidriver gearbox. Disassembly, assembly and checking of failures.....	31
■ C0503 · Scania Opticruise gearbox. Disassembly, assembly and checking of failures 	32
■ C0504 · Mercedes-Benz Powershift gearbox. Disassembly, assembly and checking of failures 	33

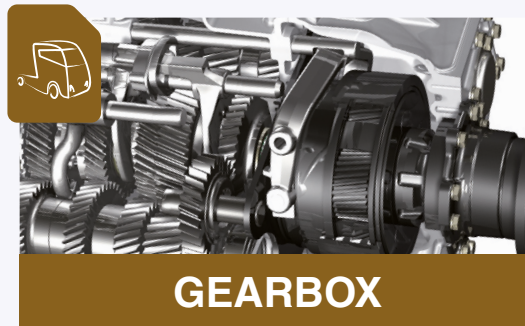



C0501

ZF AS - TRONIC GEARBOX. DISASSEMBLY, ASSEMBLY AND CHECKING OF FAILURES

Description

Theoretical-practical course.

Training course where you can study the main Gearboxes with electronic control equipped by the seven major European brands of commercial vehicles.

Study of a ZF As-Tronic gearbox.

A ZF ASTronic gearbox is disassembled and reassembled in order to identify, in a practical way, each of the sensors and the main electronic and mechanical components.

The potential of Jaltest in ZF ASTronic is analysed in a practical way (Diagnosis, actuation of solenoid valves and signal measuring).

Objective

Learn the operation of the ZF AS-Tronic gearboxes and its main breakdowns.

Learn how to disassemble and reassemble the gearbox by using the appropriate tools.

Learn the meaning of the values measured with Jaltest in diagnosis.

Net Price:
500 €

Duration_16 Hours

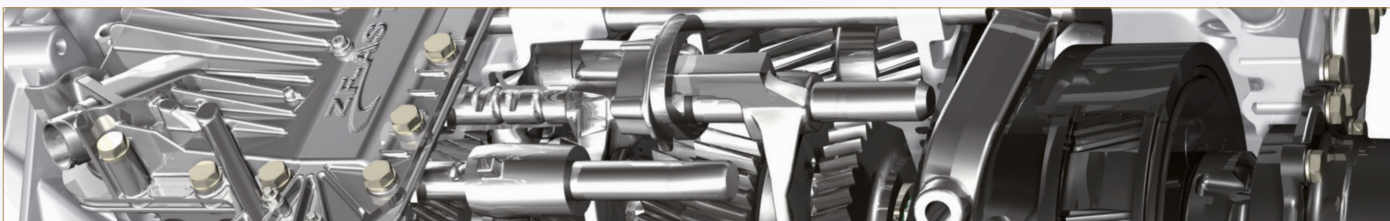



C0502

VOLVO I-SHIFT / RENAULT OPTIDRIVER GEARBOX. DISASSEMBLY, ASSEMBLY AND CHECKING OF FAILURES

Description

Theoretical-practical course.

Training course where you can study the main Gearboxes with electronic control equipped by the seven major European brands of commercial vehicles, especially I-SHIFT.

Study of an I-Shift gearbox. An I-SHIFT Gearbox is disassembled and reassembled, that way, it is possible to identify, in a practical way, each and every one of the sensors and the main electronic and mechanical components.

The solenoid valves are actuated, the signals are measured and the gearbox is calibrated in a practical way.

Net Price:
500 €

Objective

Learn the operation of the I-Shift gearboxes and its main breakdowns.

Learn how to disassemble and reassemble the gearbox by using the appropriate tools.

Learn the meaning of clutch wearing value.

Learn the meaning of the values measured with Jaltest regarding a clutch disc wearing.

Duration_16 Hours



 New Course

C0503

SCANIA OPTICRUISE GEARBOX. DISASSEMBLY, ASSEMBLY AND CHECKING OF FAILURES

Description

Theoretical-practical course.

Training course where you can study the main Gearboxes with electronic control equipped by the seven major European brands of commercial vehicles.

Study of a Scania Opticruise gearbox. A Scania Opticruise gearbox is disassembled and reassembled in order to identify, in a practical way, each of the sensors and the main electronic and mechanical components.

The potential of Jaltest in Scania Opticruise is analysed in a practical way (Diagnosis, actuation of solenoid valves and signal measuring).

Objective

Learn the operation of the Scania Opticruise gearboxes and its main breakdowns.

Learn how to disassemble and reassemble the gearbox by using the appropriate tools.

Learn the meaning of the values measured with Jaltest in diagnosis.

Net Price:
500 €

Duration_16 Hours





C0504

MERCEDES-BENZ POWERSHIFT GEARBOX. DISASSEMBLY, ASSEMBLY AND CHECKING OF FAILURES

Description

Theoretical-practical course.

Training course where you can study the main Gearboxes with electronic control equipped by the seven major European brands of commercial vehicles.

Study of a Mercedes-Benz Powershift gearbox. A Mercedes-Benz Powershift Gearbox is disassembled and reassembled, that way, it is possible to identify, in a practical way, each and every one of the sensors and the main electronic and mechanical components.

The potential of Jaltest in Mercedes-Benz Powershift is analysed in a practical way (Diagnosis, actuation of solenoid valves and signal measuring).

Objective

Learn the operation of the Mercedes-Benz Powershift gearboxes and its main breakdowns.

Learn how to disassemble and reassemble the gearbox by using the appropriate tools.

Learn the meaning of the values measured with Jaltest in diagnosis.

Net Price:
500 €

Duration_16 Hours



3.6 Comfort systems

■ C0601 · Installation of refrigeration systems with fluorinated refrigerants for the thermal comfort of human beings in vehicles.....35





C0601

INSTALLATION OF REFRIGERATION SYSTEMS WITH FLUORINATED REFRIGERANTS FOR THE THERMAL COMFORT OF HUMAN BEINGS IN VEHICLES

Description

Theoretical-practical course.

Study of the air conditioning and climate control systems for vehicles in general (cars, vans, trucks, buses, agricultural vehicles and industrial machinery) using fluorinated refrigerants (R 134a, etc. including substances which are detrimental for the ozone layer R12).

This course is divided in two main parts:

- A. ENVIRONMENTAL IMPACT AND REGULATIONS ON FLUORINATED REFRIGERANTS.
- B. MANAGEMENT OF CLIMATE CONTROL SYSTEMS IN VEHICLES.

Net Price:
500 €

Objective

Train the technicians to manage cooling systems with fluorinated refrigerants for the thermal comfort of human beings in vehicles.

..... *Duration_16 Hours*

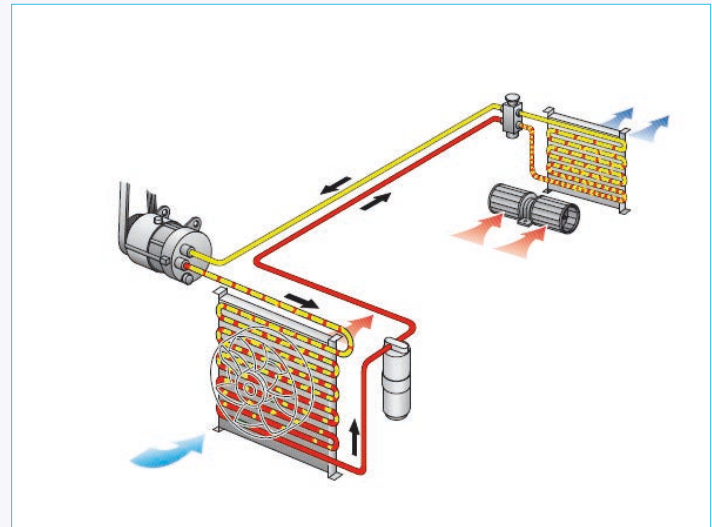

3.7 Brands

■ C0701 · Iveco. Diagnosis of EDC systems.....	37
■ C0702 · MAN TGA. Frequent failures.....	38
■ C0703 · Mercedes-Benz Actros 2/3. Frequent failures.....	39
■ C0704 · Iveco Stralis. Frequent failures.....	40
■ C0705 · Renault Premium DXi. Frequent failures.....	41
■ C0706 · MAN. Diagnosis of EDC systems.....	42
■ C0707 · Renault. Diagnosis of EDC systems.....	43





C0701

IVECO. DIAGNOSIS OF EDC SYSTEMS

Description

Analysis of the actuators and measurements developed by Jaltest in EDC systems from Iveco (EDC M7, EDC MS 6.2, EDC 7 UC 31 Cursor engine and EDC 7 UC 31 Tector engine) such as:

- ACCELERATOR PEDAL
- TURBO
- ENGINE BRAKE SOLENOID VALVE
- PREHEATING RESISTANCE

Objective

Understand the actuators and measurements in EDC systems from Iveco.

Net Price:
500 €

Duration_16 Hours





C0702

MAN TGA. FREQUENT FAILURES

Description

Check the frequent failures in a practical way taking into account the symptoms in the main systems:

- EDC
- ECAS
- AS-Tronic
- EBS

Objective

Discover the frequent failures in MAN TGA in a practical way.



Duration_16 Hours





C0703

MERCEDES-BENZ ACTROS 2/3. FREQUENT FAILURES

Description

Check the frequent failures in a practical way taking into account the symptoms in the main systems:

- MR
- SCR BlueTec
- GS
- BS

Objective

Discover the frequent failures in Mercedes-Benz Actros 2/3 in a practical way.

Net Price:
500 €

Duration_16 Hours





C0704

IVECO STRALIS. FREQUENT FAILURES

Description

Check the frequent failures in a practical way taking into account the symptoms in the main systems:

- *Engine Management*
- *Brake*
- *Gearbox*
- *Suspension*
- *Electronic Module*

Objective

Discover the frequent failures in Iveco Stralis in a practical way.

Net Price:
500 €

Duration_16 Hours





C0705

RENAULT PREMIUM DXI. FREQUENT FAILURES

Description

Check the frequent failures in a practical way taking into account the symptoms in the main systems:

- Optidriver +
- EDC injection pump
- APM
- ECS (suspension system)
- EBS

Objective

Discover the frequent failures in Renault Premium Dxi in a practical way.

Net Price:
500 €

Duration_16 Hours





C0706

MAN. DIAGNOSIS OF EDC SYSTEMS

Description

Analysis of the actuators and measurements developed by Jaltest in EDC systems from MAN (EDC M7, EDC MS 5, EDC MS 6.1, EDC MS 6.4 and EDC 7) such as:

- EGR valve
- Turbo
- Cylinders test
- Cylinders balance

Objective

Understand the actuators and measurements in EDC systems from MAN.

Net Price:
500 €

Duration_16 Hours

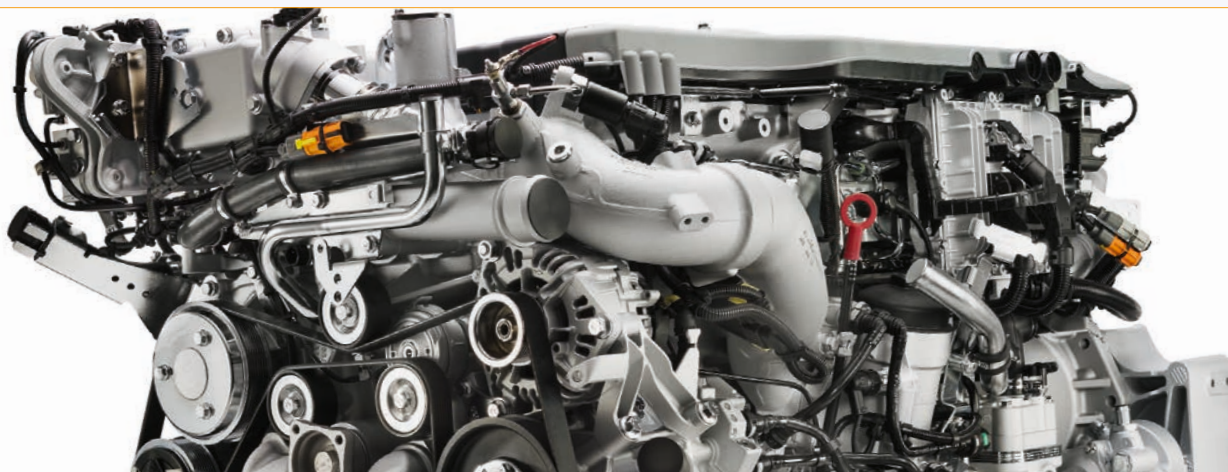



C0707

RENAULT. DIAGNOSIS OF EDC SYSTEMS

Description

Analysis of the actuators and measurements developed by Jaltest in EDC systems from Renault (VMAC, ITC, Dci, E-Tech and EMS) such as:

- Intake air temperature
- Speed limit
- Fan regulation
- Compression test
- Cylinders balance

Objective

Understand the actuators and measurements in EDC systems from Renault.

Net Price:
500 €

Duration_ **16 Hours**

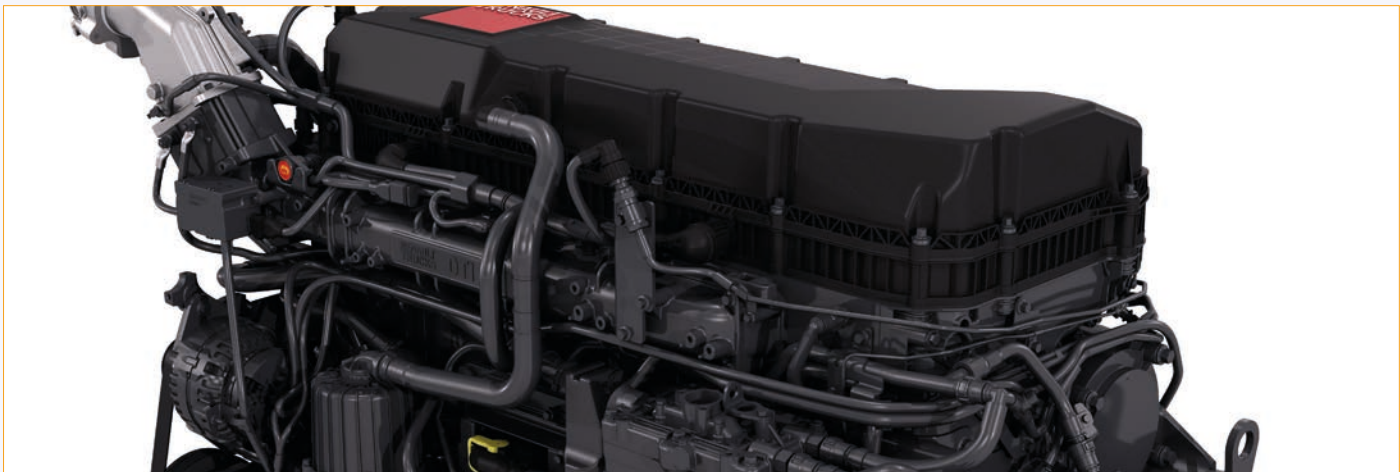

3.8 Trailer

■ C1001 · ABS trailer. Diagnosis and configuration of parameters.....	45
■ C1002 · EBS trailer. Diagnosis and configuration of parameters 	46





C1001

ABS TRAILER. DIAGNOSIS AND CONFIGURATION OF PARAMETERS

Description

Theoretical-practical course.

Description of different ABS brake systems installed in towed vehicles such as:

- ABS MODAL
- Modular/PLC
- KB3 TA
- KB4 TA
- VARIO C
- VCS
- VCS II
- e-ABS

Net Price:
500 €

Individual study of the valves and sensors that make up the systems previously described such as:

- ABS relay modulator
- Emergency relay valve

Objective

Train the technician to learn the trailer ABS systems manufactured by Wabco, Knorr and Haldex.

Duration_16 Hours

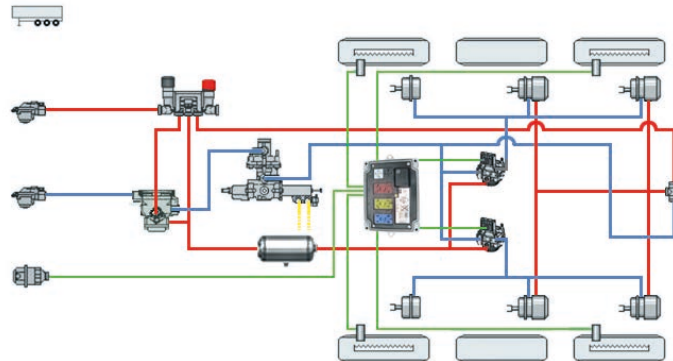

 Updated content

C1002

EBS TRAILER. DIAGNOSIS AND CONFIGURATION OF PARAMETERS

Description

Theoretical-practical course.

Description of different EBS brake systems installed in towed vehicles such as:

- Trailer EBS C, D and E
- Trailer EBS TEBS4 and GEN 2
- Trailer EBS Haldex EB+, GEN 2 and GEN 3

Individual study of the valves and sensors that make up the systems previously described such as:

- EBS modulator
- EBS relay modulator
- Relay emergency valve
- Lift axle valve
- Load pressure sensor

Net Price:
500 €

Objective

Train the technician so he learns about the trailer EBS systems manufactured by Wabco, Knorr and Haldex.

Duration_ **16 Hours**



3.9 Light commercial vehicle

- C2301 · ABS in light commercial vehicles. Diagnostics, diagrams and system checks.....**48**
- C2401 · EGR, particulate filters and AdBlue in light commercial vehicles. Diagnosis, reset and regeneration.....**49**





C2301

ABS IN LIGHT COMMERCIAL VEHICLES. DIAGNOSTICS, DIAGRAMS AND SYSTEM CHECKS

Description

Description of the main components of conventional hydraulic brake systems and ABS such as:

- Master cylinder
- Brake servo
- Pressure regulating valve based on the load (Load sensing valve)
- Drum brakes
- Disc brakes
- Speed sensors
- ABS hydraulic modulators

Net Price:
500 €

..... *Duration_16 Hours*

Objective

Train the technician on trailer ABS hydraulic systems from light commercial vehicles.

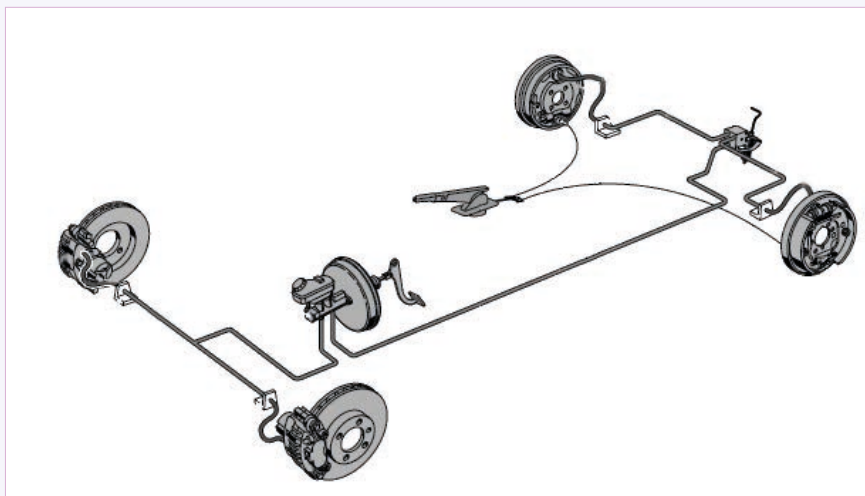



C2401

EGR, PARTICULATE FILTERS AND ADBLUE IN LIGHT COMMERCIAL VEHICLES. DIAGNOSIS, RESET AND REGENERATION

Description

Study of the EGR and exhaust gas treatment systems on the main brands of light vehicles. Diagnosis and reset possibilities of the adaptation values, EGR system test, particulate filter regeneration, measuring of the differential pressure sensor of the particulate filter, lambda probe measurement...

Objective



Train the technician on the main exhaust gas aftertreatment systems in light commercial vehicles.

Net Price:
500 €

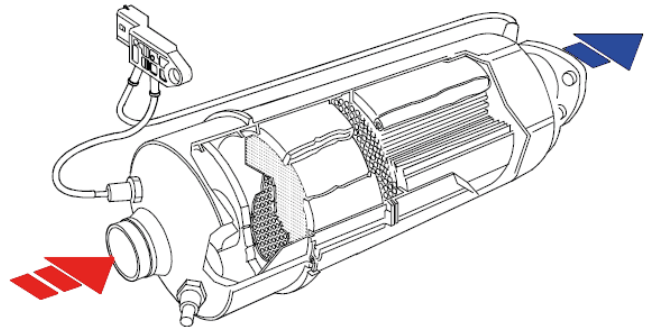
Duration_16 Hours



3.10 Agricultural Vehicles

■ C3101 · Jaltest AGV. Use of the device and diagnostics 	51
■ C3201 · Electricity in agricultural vehicles. Reading of wiring diagrams 	52





C3101

JALTEST AGV. USE OF THE DEVICE AND DIAGNOSTICS

Description

Course to acquire the necessary knowledge about the main systems with electronic control in order to interpret the diagnosis in agricultural vehicles correctly.

We perform diagnosis in the different systems with electronic control.

- *Brake systems: BRC, brake system*
- *Engine management system: HPCR CP3, Common Rail*
- *Gearbox: EPC, Transmission / PTI, Transmission*
- *Hydraulic systems: HCU, hydraulic lift*
- *Electronic modules: TEC, implement controller*
- *Powertrain: PTO, power take-off*

Net Price:
500 €

Duration_ **16 Hours**

Objective

Train the technician to diagnose the main systems in an agricultural vehicle.





C3201

ELECTRICITY IN AGRICULTURAL VEHICLES. READING OF WIRING DIAGRAMS

Description

Study of the basic concepts of electricity, such as: tension, direct current, alternating current, resistance, power, short circuits, open circuits, square signals...

Interpretation and checking of wiring diagrams, sensors and electronic components from different brands of agricultural vehicles with the help of the appropriate documentation and material.

Objective

Advanced handling of the multimeter by dealing with real failures caused on test benches.

Differentiate between the main units of measurement and electrical parameters.

Analyse electrical signals both theoretically and practically with the help of an oscilloscope.

Net Price:
500 €

Duration_16 Hours

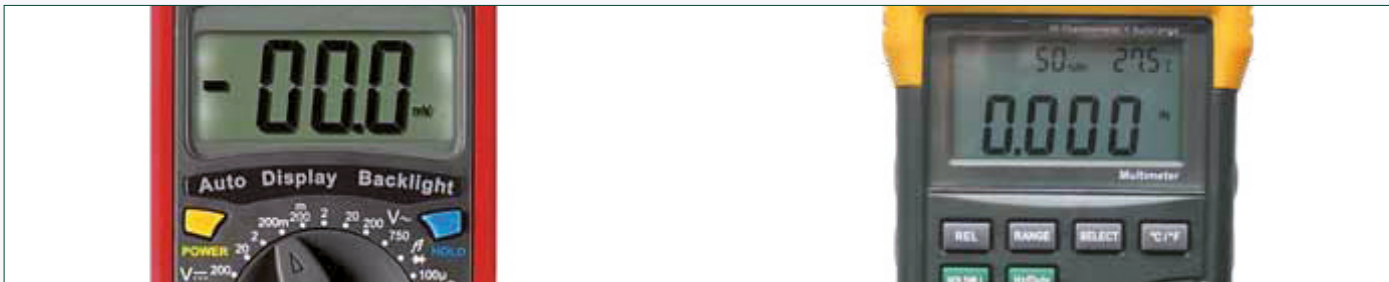

3.11 Jaltest Specialist

■ C9901 · Repair Methods in commercial vehicles.....54





C9901

REPAIR METHODS IN COMMERCIAL VEHICLES

Description

Practical course.

Practical tests on different vehicles and systems by performing diagnosis with Jaltest. 100% practical course.

Objective

Train the mechanic on the repair of failures in a practical way.

Net Price:
500 €

Duration_16 Hours



e-LEARNING



**ANY PLACE,
TRAINING TO ITS FULL EXTENT**





PF_EN_16.1.2

Cojali S.L.
Avenida de la Industria, S/N · 13610
Campo de Criptana · Ciudad Real · Spain
Tel. +34 926 589 670 / 671 · Fax: 926 589 672
cojali@cojali.com · www.cojali.com · www.jaltest.com

